

900-1120nm High Power Free Space Isolator

FEATURES

- High Isolation
- Low Insertion Loss
- Epoxy-Free Optical Path
- High Reliability and Stability
- Low Profile Packaging

APPLICATIONS

- Broadband Systems
- Optical Amplifying Systems
- Telecommunication Networks
- Metro Networks
- CATV Networks

SPECIFICATIONS

Parameter	Unit	High Power Type
Center Wavelength (λ_c)	nm	915, 930, 950, 975 1020, 1030, 1040, 1053, 1064 1070, 1080, 1092, 1103, 1120
Operating Wavelength Range	nm	+/-10
Peak Isolation (Typ.)	dB	~30
Min. Isolation (23°C)	dB	22
Typical Insertion Loss (λ_c , 23°C)	dB	0.4
Max. Insertion Loss (λ_c , 23°C)	dB	0.7
Clear Aperture	mm	2.0, 3.0, 5.0
Input Polarization Plane	-	Horizontal, Vertical
Output Polarization Plane	-	Horizontal, Vertical or 45degree
Maximum Optical Power (CW)	W	1, 2, 3, 5, 10, 20, 30, 40, 50, 60, 80, 100
Operating Temperature	°C	0~50
Storage Temperature	°C	-20~75

- Note:**
1. Devices for higher optical power and pulse power are also available.
 2. Package dimensions may be different for different clear aperture and optical power.

PACKAGE DIMENSION

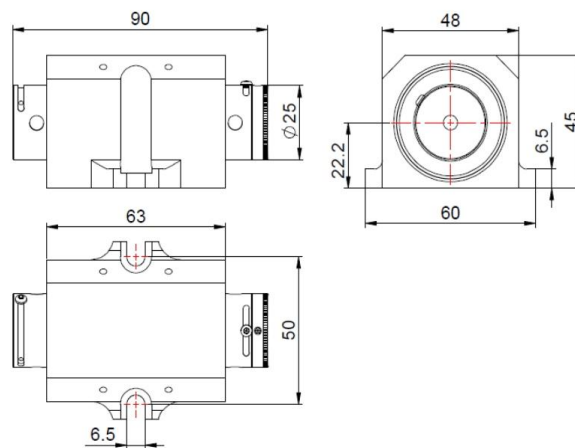

ORDERING INFORMATION (PN)

FISF-NNNN	-HP NN	- NN	C	C
Center Wavelength	Optical Power	Clear Aperture	Input Direction	Output Direction
975-975nm	3-3W	20-2.0mm	H=Horizontal	H=Horizontal
1030-1030nm	10-10W	30-3.0mm	V=Vertical	V=Vertical
1064-1064nm	20-20W	50-5.0mm		Q=45degree
1092-1092nm	50-50W			