

2000nm 2x2 Polarization Beam Combiner/Splitter

FEATURES

- High Isolation
- Low Insertion Loss
- High Reliability and Stability
- Various Bandwidth
- High Optical Power

APPLICATIONS

- Broadband Systems
- Optical Amplifying Systems
- Telecommunication Networks
- Research Labs
- Laser Systems

SPECIFICATIONS

Parameter	Unit	Value	
Center Wavelength	nm	1900, 1950, 2000, 2050	
Bandwidth	nm	+/-20	
Insertion Loss (Port 3 to Port 1/2 at Slow Axis, Port 4 to Port 1/2 at Fast Axis)	(Typ.)	dB	1.0
	(Max.)	dB	1.6
Optical Return Loss	dB	≥45	
Extinction Ratio (for FPDS)	(Typ.)	dB	22
	(Min.)	dB	20
Fiber Type of Port 1 & Port 2	-	PM1550 Panda Fiber or PM1950 Fiber (V) 10/130um PMDC Fiber (O) or 25/400um PMDC Fiber (R)	
Fiber Type of Port 3 & Port 4	S Type	-	Corresponding SM Fiber
	P Type	-	Same Fiber to Port1&2, Slow axis align to Port 1 Slow/Fast axis
	Q Type	-	Same Fiber to Port1&2, Slow axis is 45° to Port 1 Slow/Fast axis
Fiber Tensile Load	N	5	
Max. Optical Power (CW)	mW	300	
Operating Temperature	°C	0~50	
Storage Temperature	°C	-40~85	

- Note:**
- Specifications are for device without connectors; Specifications may change without notice.
 - To add connectors, IL is 0.3dB higher, RL is 5dB lower, ER is 2dB Lower, Connector key is aligned to slow axis.
 - Devices for higher optical power or with other type fiber or consigned fiber are also available; Devices can only work in the core of Double Cladding (DC) Fiber, Cladding Power must be stripped before connecting the device.
 - Package size may be different for different fiber type.

LIGHT ROUTE

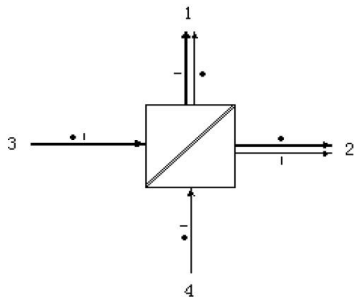

PACKAGE DIMENSION

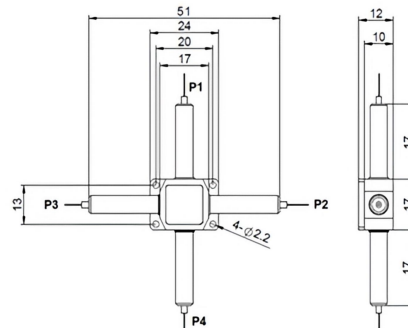

ORDERING INFORMATION (PN) FPDC=Polarization Beam Combiner; FPDS=Polarization Beam Splitter.

FPDC / FPDS	NNNN <small>Center Wavelength</small>	C <small>3rd Port Fiber</small>	C <small>4th Port Fiber</small>	C <small>Fiber Type</small>	C <small>Fiber Sleeve</small>	NN <small>Fiber Length</small>	-CC/CCC <small>Connector Type</small>
	1900-1900nm	S=S Type	S=S Type	2-PM1550Fiber	B= Bare fiber	05=0.5m	N=Without Connector
	1950-1950nm	P=P Type	P=P Type	V-PM1950 Fiber	L= Loose Tube	10=1.0m	FC/APC=FC/APC Connector
	2000-2000nm	Q=Q Type	Q=Q Type	O=10/130 PMDC Fiber	2= 2mm Cable	15=1.5m	LC/PC=LC/PC Connector
	2050-2050nm			R=25/400 PMDC Fiber	3= 3mm Cable	20=2.0m	SC/UPC=SC/UPC Connector

