

750~850nm 2x2 PBC/PBS for Pulse

FEATURES

- High Isolation
- Low Insertion Loss
- High Reliability and Stability
- Various Bandwidth
- High Optical Power

APPLICATIONS

- Broadband Systems
- Optical Amplifying Systems
- Telecommunication Networks
- Research Labs
- Laser Systems

SPECIFICATIONS

Parameter	Unit	Value	
Center Wavelength	nm	760, 780, 793, 808	830, 850
Bandwidth	nm	+/-10	
Insertion Loss (Port 3 to Port 1/2 at Slow Axis, Port 4 to Port 1/2 at Fast Axis)	(Typ.)	0.9	0.8
	(Max.)	1.6	1.4
Optical Return Loss	dB	≥45	
Extinction Ratio (for FPDS)	(Typ.)	22	
	(Min.)	18	
Fiber Type of Port 1 & Port 2	-	PM850 Fiber or PM780-HP Fiber	
Fiber Type of Port 3 & Port 4	S Type	Corresponding SM Fiber	
	P Type	Same Fiber to Port1&2, Slow axis align to Port 1 Slow/Fast axis	
	Q Type	Same Fiber to Port1&2, Slow axis is 45° to Port 1 Slow/Fast axis	
Fiber Tensile Load	N	5	
Max. Average Optical Power	W	0.3, 0.5, 1, 2, 3, 5, 10, 15, 20	
Max. Peak Power for pulse	kW	0.1, 1, 2, 3, 5, 10, 15, 20	
Operating Temperature	°C	0~50	
Storage Temperature	°C	-40~85	

- Note:**
- Specifications are for device without connectors; Specifications may change without notice.
 - To add connectors, IL is 0.7dB higher, RL is 5dB lower, ER is 2dB Lower, Connector key is aligned to slow axis.
 - Only guarantee 1W continuous wave (CW) power thru testing for connectors added.
 - Devices for higher optical power or with other type fiber or consigned fiber are also available; Devices can only work in the core of Double Cladding (DC) Fiber, Cladding Power must be stripped before connecting the device.
 - Package size may be different for different optical power and fiber type.

LIGHT ROUTE

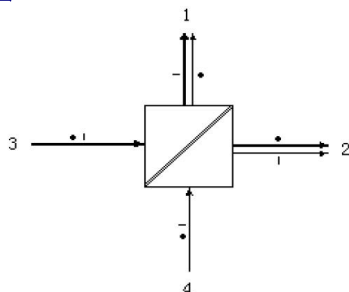

PACKAGE DIMENSION

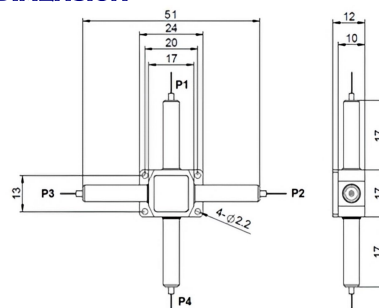

ORDERING INFORMATION (PN) FPDC=Polarization Beam Combiner; FPDS=Polarization Beam Splitter.

FPDC / FPDS	NNN	C	C	H	NN	P NN	C	C	NN	CC/CCC
	Center Wavelength	3rd Port Fiber	4th Port Fiber	Average Power	Peak Power	Fiber Type	Fiber Sleeve	Fiber Length	Connector Type	
	780-780nm	S=S Type	S=S Type	03=300mW	01=100W	2-PM850 Fiber	B= Bare fiber	05=0.5m	N=Without Connector	
	793-793nm	P=P Type	P=P Type	1= 1W	1= 1kW	7-PM780HP Fiber	L= Loose Tube	10=1.0m	FC/APC=FC/APC Connector	
	830-830nm	Q=Q Type	Q=Q Type	5= 5W	5= 5kW		2= 2mm Cable	15=1.5m	LC/PC=LC/PC Connector	
	850-850nm			10=10W	10=10kW		3= 3mm Cable	20=2.0m	SC/UPC=SC/UPC Connector	