

2000nm High Power Manual VOA

FEATURES

- Low Excess Loss
- Various Splitting Ratio
- Wide Passband
- High Stability and Reliability
- Epoxy Free Optical Path

APPLICATIONS

- Optical Amplifier
- Optical Networks
- Power Monitoring
- Fiber Sensor
- Labs



SPECIFICATIONS

Parameter	Unit	Value
Center Wavelength	nm	1900, 1950, 2000, 2050
Bandwidth	nm	+/-20
Attenuation Range	dB	1.0~30
Resolution (<10dB attenuation)	dB	0.3
PDL (at lowest attenuation)	dB	≤0.2
Optical Return Loss	dB	≥45
Fiber Type	-	SMF-28 Fiber or SM1950 Fiber (V) 10/130um DC Fiber (O) or 25/250um DC Fiber (R)
Fiber Tensile Load	N	5
Max. Thru Optical Power (CW)	W	1, 2, 3, 5, 10
Max. Attenuated Optical Power (CW)	W	2
Operating Temperature	°C	0~50
Storage Temperature	°C	-40~85

- Note:**
1. Specifications are for device without connectors; Specifications may change without notice.
 2. To add connectors, IL is 0.3dB higher, RL is 5dB lower.
 3. Only guarantee 1W continuous wave (CW) power thru testing for connectors added.
 4. Devices for higher optical power or with other type fiber or consigned fiber are also available; Devices can only work in the core of Double Cladding (DC) Fiber, Cladding Power must be stripped before connecting the device.

PACKAGE DIMENSION

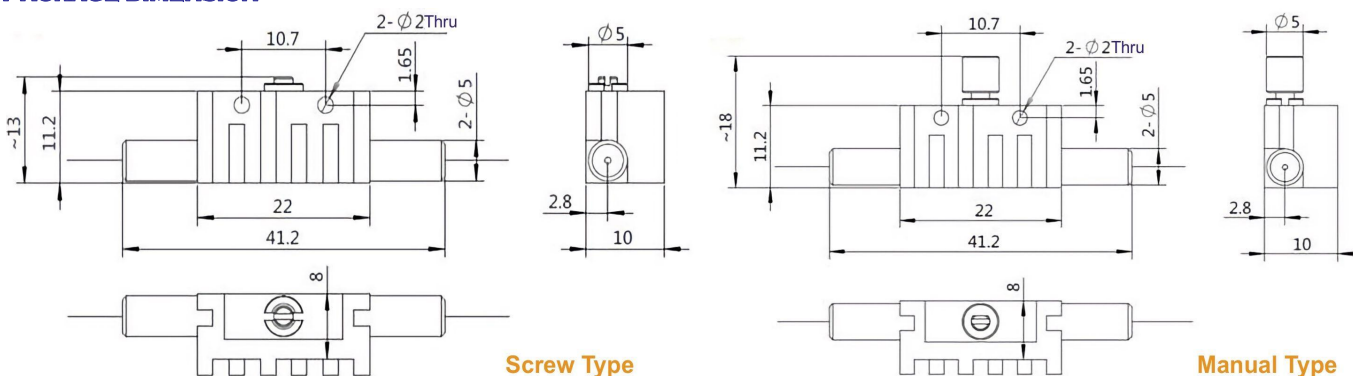

ORDERING INFORMATION (PN)

Center Wavelength	Package	Optical Power	Fiber Type	Fiber Sleeve	Fiber Length	Connector Type
1900-1900nm	M-Manual Type	1-1W	V-SM1950 Fiber	B- Bare fiber	05=0.5m	N-Without Connector
1950-1950nm	Blank for Screw Type	2-2W	O=10/130 DC Fiber	L- Loose Tube	10=1.0m	FC/APC=FC/APC Connector
2000-2000nm		5-5W	R=25/250 DC Fiber	2- 2mm Cable	15=1.5m	LC/PC=LC/PC Connector
2050-2050nm		10=10W	Blank for SMF-28 Fiber	3- 3mm Cable	20=2.0m	SC/UPC=SC/UPC Connector