

## 900~960nm High Power Manual VOA

### FEATURES

- ▣ Low Excess Loss
- ▣ Various Attenuation
- ▣ Wide Passband
- ▣ High Stability and Reliability
- ▣ Epoxy Free Optical Path

### APPLICATIONS

- ▣ Optical Amplifier
- ▣ Optical Networks
- ▣ Power Monitoring
- ▣ Fiber Sensor
- ▣ Labs



### SPECIFICATIONS

Parameter	Unit	Value
Center Wavelength	nm	915, 930, 940, 950
Bandwidth	nm	+/-15
Max. Insertion Loss	dB	1.2
Attenuation Range	dB	0.8~30
Resolution (<10dB attenuation)	dB	0.2
PDL (at lowest attenuation)	dB	≤0.2
Optical Return Loss	dB	≥45
Fiber Type	-	HI780 Fiber, HI1060 Fiber or 10/125um SC Fiber (E) 10/125um DC Fiber (O), 15/130um DC Fiber (W) 20/130um DC Fiber (Q) or 25/250um DC Fiber (R)
Fiber Tensile Load	N	5
Max. Thru Optical Power (CW)	W	1, 2, 3, 5, 10
Max. Attenuated Optical Power (CW)	W	2
Operating Temperature	°C	0~50
Storage Temperature	°C	-40~85

**Note:** 1. Specifications are for device without connectors; Specifications may change without notice.

2. To add connectors, IL is 0.7dB higher, RL is 5dB lower.

3. Only guarantee 1W continuous wave (CW) power thru testing for connectors added.

4. Devices for higher optical power or with other type fiber or consigned fiber are also available; Devices can only work in the core of Double Cladding (DC) Fiber, Cladding Power must be stripped before connecting the device.

### PACKAGE DIMENSION

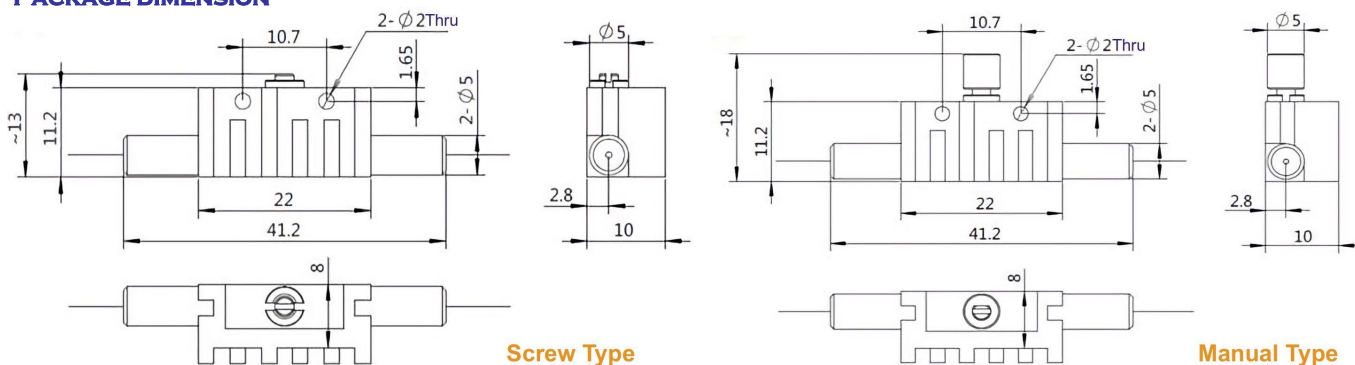

### ORDERING INFORMATION (PN)

PMVA-NNN	- (C)	HP NN	- (C)	C	NN	- CC/CCC
Center Wavelength	Package	Optical Power	Fiber Type	Fiber Sleeve	Fiber Length	Connector Type
915-915nm	M=Manual Type	1=1W	H=HI1060 Fiber	B= Bare fiber	05=0.5m	N=Without Connector
930-930nm	Blank for Screw Type	2=2W	E=10/125 SC Fiber	L= Loose Tube	10=1.0m	FC/APC=FC/APC Connector
940-940nm		5=5W	R=25/250 DC Fiber	2= 2mm Cable	15=1.5m	LC/PC=LC/PC Connector
950-950nm		10=10W	Blank for HI780 Fiber	3= 3mm Cable	20=2.0m	SC/UPC=SC/UPC Connector

